

SUNFLEXX[®]

LATERAL ARM AWNING

PARTS LIST

1. Arm Clamp
2. Roller tube End Plate #_ E543
3. Support Tube #-_E526
4. Front Rail # _E527
5. Lateral Arms # _A529 thru #_ A533
6. Roller Tube # ME525
7. 3:1 or 7.8:1 Ratio Bevel Gear # _A541 or # _A542
8. Roller Tube End Cap w/Round Pin #BP538
9. Hood Wall Bracket # _E519
10. Front Rail End Cap # _P546
11. Arm Draw Pin Assembly
12. Lateral Arm End Assembly
13. Roller Tube End Cap Bushing
14. Hood Profile #_E510
15. Hood End Cover #_511

Replace the spaces in the Product Category numbers with a W for White, a B for Bronze or an S for Silver Finish.



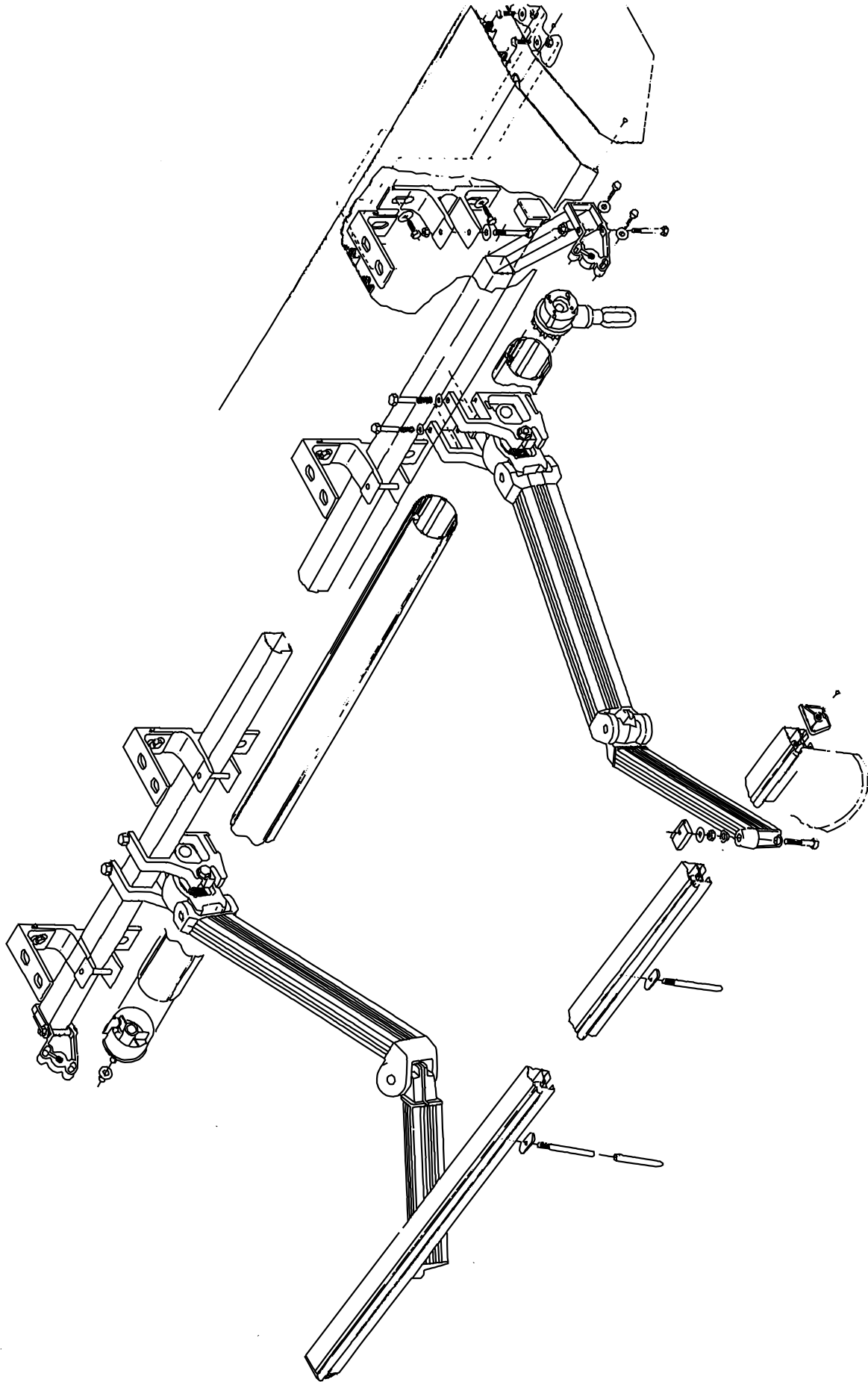

Installation Instructions

Congratulations! You have purchased the finest lateral arm awning on the market. "SunFlexx"® is completely pre-assembled and factory tested; it is specifically designed for easy installation.

Before beginning, please familiarize yourself with the components of the awning as shown on the accompanying diagram. It will save you time in the long run. Find the mounting brackets; they will be one of the three types designed specifically for your installation. Brackets #518 and #519 are for wall mounting. Bracket #520 is used for soffit mounting.

The length of the awning determines the number of brackets. A 6 ft long awning will have two brackets, a 12 ft, three, a 16 ft, four, and a 21 ft, six brackets. Use all brackets for secure mounting.

TOOLS REQUIRED

Electric drill, 1/8" and 1/4" drill bit, two 9/16" and one - 3/4" wrenches or sockets, #1 Phillips screwdriver, stud finder (for wood frame construction), 1' and 4' levels, and chalk line. A heavy duty mason drill with a carbide bit is required to install brackets on masonry walls.

LOCATING THE BRACKETS

Proper location of the brackets is the most important aspect of the "Sunflexx" mounting. They must be fastened to studs, joists, headers or other major structural members. Even a moderate wind exerts great force on the awning and mounting brackets. This is why it is most important that all "Sunflexx" mounting brackets be fastened properly and securely. Proper location will also make it easier to insert the support tube when hanging the awning. Included on page one of these instructions is a diagram of a typical two arm "Sunflexx" awning. Mounting points

and the components of the awning have been numbered for easy reference.

You will find points A, B, and C on the support tube (#3) are recommended positions for the mounting brackets. When only two brackets per awning are required, the mounting brackets must be located at points A, and within 12" of center to (#1) arm clamp and (#2) bearing end plate. If a third mounting bracket is required, it must be located at point C on the support tube (#3) within 12" of center between the two arm clamps (#1). When two brackets per arm are needed, locate one bracket within 12" of center to the arm clamp (#1) and the bearing end plate (#2). The second bracket must not be more than 14" from the arm clamp (#1) at mounting point B on the support tube (#3).

To determine the proper height of the mounting brackets refer to page five of these installation instructions and locate the pitch chart which relates to your awning. Next find the projection on the pitch chart which matches that of the one you are installing. Add the number of inches that are needed from the pitch chart to the height at which you prefer the front rail (#4) when the awning is fully extended. This is considered the optimum installation height but not always obtainable due to low roof heights. Next, snap a level chalk line along the wall at the height you have determined to be the top of the bracket. Make a mark on the wall at the end points of the awning and at the arm clamps (#1). Note: If your awning has a soft roller center support #_A545, be sure not to locate a wall bracket where it will interfere with the roller support when the awning is mounted in the brackets. If your awning has a soft roller center support, be sure to install the roller support top before placing the awning into the wall brackets.

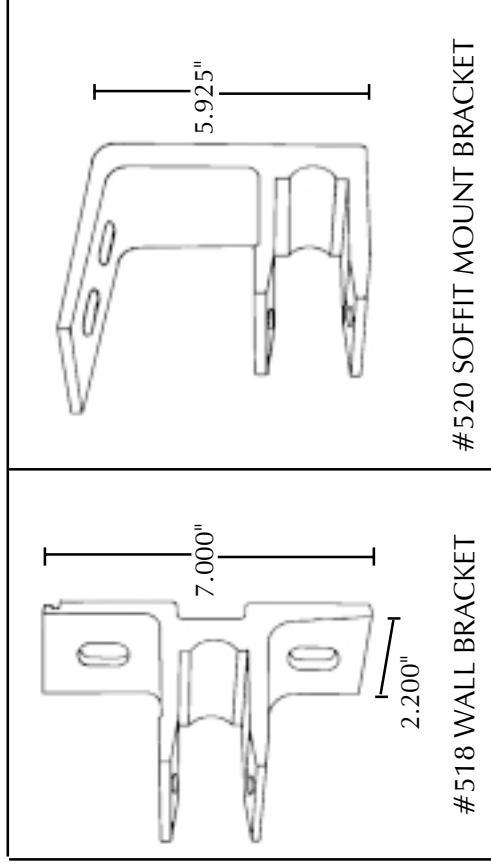

#518 WALL BRACKET

#520 SOFFIT MOUNT BRACKET

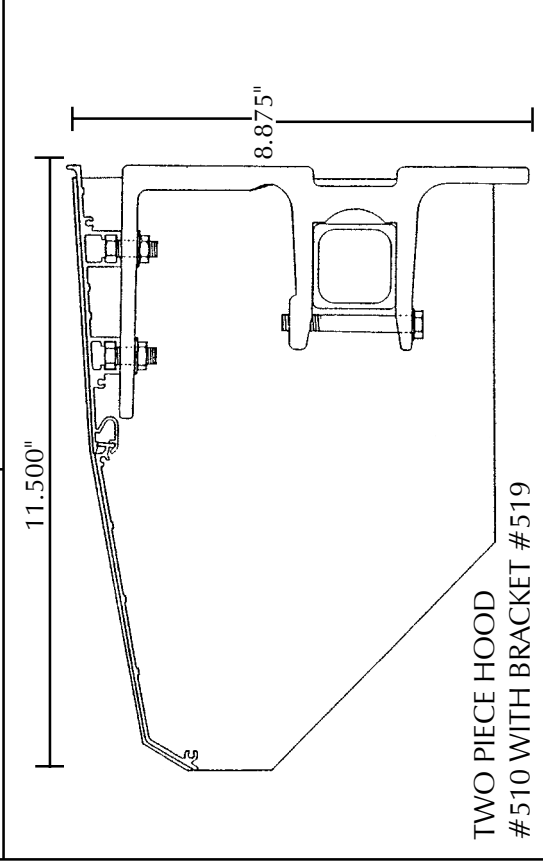

TWO PIECE HOOD #510 WITH BRACKET #519

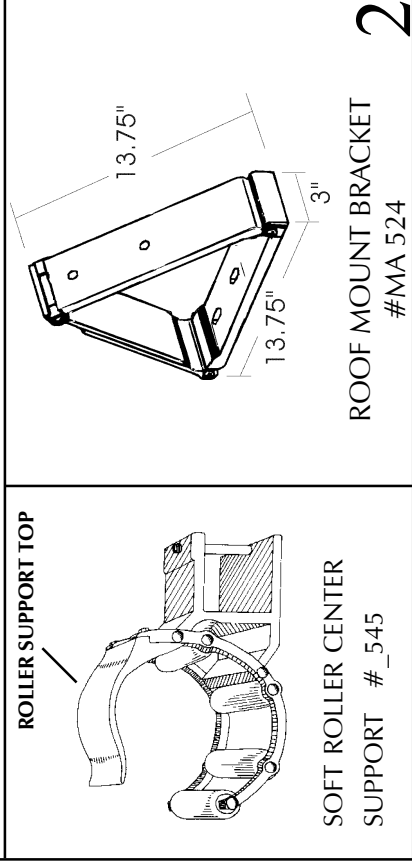

SOFT ROLLER CENTER SUPPORT #_545

ROOF MOUNT BRACKET #MA 524

INSTALLING THE BRACKETS ON WOOD FRAMED WALLS

You must first locate the studs, joists or header in the area in which the bracket must be installed as explained earlier in **LOCATING THE BRACKETS**. To find the stud or joist, measure from the edge of a window or door to the approximate area where the bracket is being installed, then on the inside of the wall measure from the same window or door to the same area, and with a stud finder locate the stud and transfer your dimension to the outside wall. Next drill horizontally a series of 1/8" holes approximately 1" below the chalk line at the mounting point to locate the edge of the stud or framing. Then measure to the center of the stud and draw a 7" vertical level line. (Never guess to the center of the stud.)

Position the bracket holes, centered over the vertical level line and the top of the bracket, even with the horizontal chalk line. Mark both bracket holes and drill 1/4" pilot holes square to the wall 2 1/2" into the stud or joist. This will prevent the framing from splitting while installing the lags. Use a silicone sealant to fill all of the 1/8" holes. If done properly the mounting bracket will cover all the 1/8" holes. Install the bracket with a 3/8" diameter lag using a length that will penetrate the framing 2 1/2" to 3". Use a flat washer under the head of the lag. Make sure not to over tighten the lags; to do so may split the wood framing or weaken the lag.

"SOFT" WALLS (SHINGLES, VINYL, OR ALUMINUM SIDING, CLAPBOARDS)

This type of construction requires the use of spacers or shims under the brackets to insure that they are level and to avoid crushing the soft material when the brackets are tightened. It is not advisable to cut openings in the siding and recess the brackets, since this will not allow sufficient clearance for the lateral arm clamps (#1). The best way to deal with a "soft" wall is with spacer blocks cut out of pressure treated lumber, 1" or 1 1/2" thick by the width and height of the mounting bracket. Use a spacer for each bracket. After locating the



studs for each mounting bracket, place the spacer on the siding in the exact location where your bracket is to be mounted. Trace all four sides of the spacer on the wall. Using a small circular saw to cut the siding, remove the cut piece of siding and place the spacer into the opening to assure the proper fit. Drill two 1/2" diameter holes into the spacer to align with bracket holes. Drill the two 1/4" pilot holes square into the framing for your brackets. Insert the spacer into the opening and place the mounting bracket on top and lag both into wall. Be sure to seal around the spacer and the siding. An alternative method where the "soft" wall is flat, is to lag a 2" x 8" header the length of the awning, at the proper height, and bolt the brackets, to it. With clapboards or shingles, tapered shims may also be used under the brackets.

BOWED WALLS

You may find when stretching a chalk line from one bracket to another, that the wall is bowed. In this case, either the end brackets or the intermediate brackets must be spaced outward from the wall by shims to insure proper alignment.

MASONRY OR CONCRETE WALLS

Our #518 and #519 mounting brackets are also used when installing the "Sunflex" on masonry and concrete walls. Follow the same procedure to locate each bracket as earlier explained in **LOCATING THE BRACKETS**. Always use caution when choosing masonry or concrete fasteners to mount the brackets. When mounting on any masonry or concrete surface be certain that the wall has not deteriorated. If this is the case through-bolting

may be necessary. When mounting on typical hollow core block walls you will need to through-bolt or use a high quality toggle bolt. Due to the many variations of masonry installation, we strongly recommend you call your local fastener supplier for their recommendations on choosing the proper concrete anchors.

ROOF MOUNT INSTALLATION

Locate the center of each of the roof rafters as explained in **LOCATING THE BRACKETS**, then place the roof bracket approximately 1" back from the edge of the roof.

Note: some roof edges can be severely rotted and the bracket may have to be moved accordingly.

Align the elongated holes of the lower plate over the rafters and mark their position. Carefully pilot drill a 1/4" hole at a 90 degree angle into the rafter where marked, and apply a 1/2" high bead of silicone sealant in a 2" circle around each hole. Apply a 1/2" bead of silicone sealant to the underside of the roof bracket, along the left, right and top edges to form a horseshoe of sealant leaving the bottom open.

Bolt all brackets to the roof using a 3/8" diameter lag and a length that will penetrate the rafter 2 1/2" to 3". Adjust the roof mount bracket angle accordingly and fasten the adjusting plates.

Bolt a continuous pressure treated 2" x 8" along the top edge of the roof mount brackets. Using 1/2" diameter carriage bolts fasten all "Sunflex" mounting brackets in their proper location to the 2" x 8" lumber. You may install the Sunflex mounting brackets directly to the roof mount brackets, eliminating the need for a 2" x 8" header board.

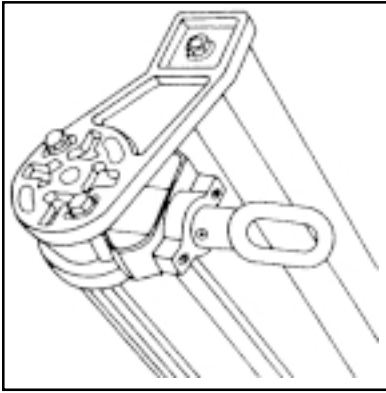

Gear Drive

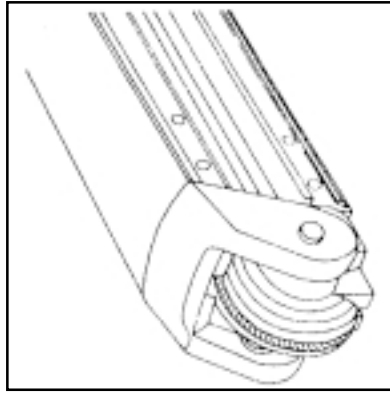

Arm Elbow Joint

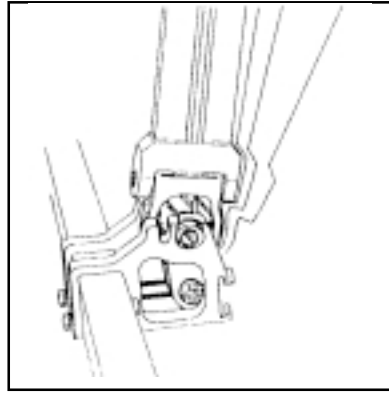

Arm Adjustment Shoulder

INSTALLING THE HOOD

It is important to install the hood before the awning. Using the 5/16" x 3/4" bolts provided, slide the correct number of bolt heads into the extruded slots of the in-board half of the hood. The number of bolts in each slot should correspond to the number of brackets. Be sure to use two hood bolts per bracket. Carefully lower the hood onto the brackets and guide the bolts through the appropriate holes. Then, using the supplied nuts and washers, carefully tighten the nuts and attach end covers.

INSTALLING THE AWNING

Leave the retaining straps in place (if provided), until installation has been completed. With proper help, lift the awning into position so the ends line up with the points marked on the ceiling or wall. Insert the retaining bolts into the brackets. Be sure to install a washer under the bolt head and then tighten securely. The retaining bolts should slip in easily. If not, slight pressure on the support tube should permit insertion. If there is still a problem, loosen the bracket mounting bolts until the retaining bolts fit, then retighten all bolts.

NOTE: If you are experiencing difficulty or do not clearly understand these installation instructions, please call Eastern Awning Systems for assistance. (860)-274-9218



**Eastern Awning Systems, Inc.
843 Echo Lake Road, Watertown, CT 06795
860-274-9218**

AWNING ADJUSTMENT AND PITCH RECOMMENDATIONS

After the awning has been installed, making sure all bolts have been tightened and packing materials removed, extend the awning to its full projection. The folding arms (#5) will still be slightly angled.

Setting the correct pitch is one of the most important details to protect the "Sunflex" from rain damage. Extend the awning to its fullest projection, keeping the fabric as taut as possible. Using a 4' level or larger, place the level on the top of the front rail and set the pitch of the fabric to the pitch chart on page five of these instructions. If there are ever questions regarding this procedure, call the factory for additional information.

Our Urethane Compression Joint is designed for easy adjustment. All that is needed is one 3/4" wrench when a up to 22 degrees of pitch is required.

When additional pitch is needed, remove the hole in the urethane center hub and replace it in the lower slots of the outer plates. Tighten the bolt with the nylock nut securely, then back off the nylock nut about 1/8 turn allowing the bolt to turn using a wrench. This ensures the Urethane Compression System will work properly. You are now able to pitch the awning as much as 45 degrees.

SUNFLEX WITH ELECTRIC MOTOR

Mount the awning in the same manner as a manually operated awning. An electrical diagram, supplied with the Somfy switch will indicate the proper connections to 120-volt AC service. Do not adjust the motor, which has been tested and preset at the factory. Before wiring two or more Somfy motors together please contact Somfy for important wiring Information.

Sunflexx installation instructions continued.

Standard Sunflexx minimum pitch recommendations to protect awning in the event of unexpected rain.

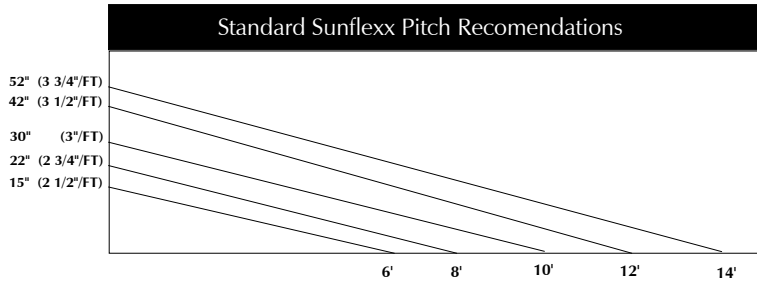

Wind and Rain Package minimum pitch requirement must be followed if awning is to be used during moderate rain.

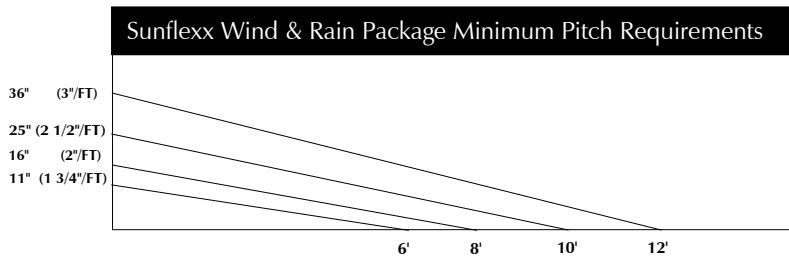

Illustrated here is a cut away view of the Sunflexx Lateral Arm Awning in its retracted storage position with an optional protective hood.

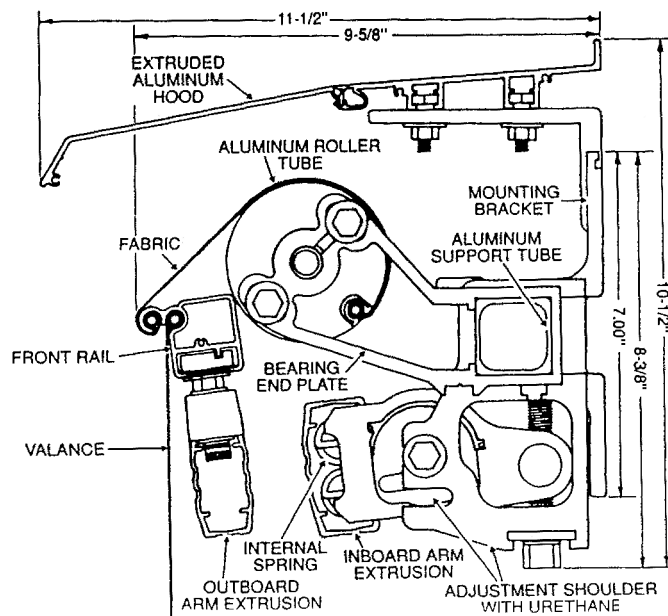

WIND & RAIN PACKAGE™ INSTALLATION INSTRUCTIONS

FIRST: Locate the Wind & Rain pitch chart on the left side of this page. Match the projection of the awning which you are installing to that on the chart. Extend your awning fully and set the pitch to at least the amount specified on the chart. NEVER pitch the awning less than what is required on the pitch chart. Be sure to level the front rail.

SECOND: Roll the awning out until the fabric starts to sag, install the stainless steel pins into each arm elbow. Then with the handcrank retract the fabric so that it is taut. (If an optional motor was purchased, NEVER RETRACT THE AWNING UNDER MOTOR POWER).

THIRD: Cut the auxiliary poles to the proper height by placing the pole on the deck with the fixture end down. Vertically align each pole with its preinstalled mating front rail socket. Mark the pole at the shoulder of the front rail socket making sure to allow that the leg of the socket will set inside the pole. After cutting each pole to your predetermined length install the auxiliary poles onto the front rail sockets. Before fastening the poles to their sockets check the front rail for level. Some adjustments to the pole lengths may be necessary if the front rail is out of level.

At the top, on both smooth sides of each pole, drill a 5/32" diameter hole 3/8" deep and 1/2" below the top of the pole and centered. Drill through the pole and into the front rail socket. Install the stainless steel pop rivets, which are supplied, into each hole.

WARNING: This system can only be purchased with a gear or manual over ride motor. To avoid awning or motor damage, properly instruct your customer to remove the pins from the lateral arms and return the auxiliary poles back to their storage position prior to retracting the awning. The Wind and Rain Package will not work properly and damage may result to the awning if the awning has inadequate pitch or the fabric is not kept taut. Possible damage may also occur to the awning if it is extended during heavy rains and / or excessive winds.